



# THINKING FORWARD

PREMIER TECH CHRONOS' RD&I WORLD



Dear Packaging Partners,

Since PREMIER TECH's inception in the late 80s, our company vision has always been long-term and never based on a short-term strategic planning. All moves were to pay off years down the road but always keeping in mind the overall orientation of the company's future and try not to deviate from it. Even back in our early years, we were thinking forward by putting in place solid RD&I programs.

At PREMIER TECH CHRONOS, Research, Development and Innovation (RD&I) programs contribute to the development of new technologies, new product options/features as well as to the continuous improvement of the existing product lines. All three are being touched upon and all three are following a very thorough research process of feasibility while following the company's strategic planning.

In the most recent months, we have been in the preliminary stages of our

next RD&I program that will take place from 2005 through 2010. This program will once again provide the opportunity for the packaging business area of PREMIER TECH to "think outside the box" and permit the launch of many more innovations. Our last program which spanned from 2000 to 2004 has introduced 7 new technologies and over 25 new options/features so far to our equipment lines in the market place. Our yearly investments surpassed 1.8 million dollars per year.

As you will notice on pages 4 and 5 of this INPACK issue, several new products have been launched already with a few more to come. I can only reassure our loyal clientele that partnering

with PREMIER TECH CHRONOS also means our total commitment to continuous improvement and upgrade of our technological platforms. At the end, this is the only way we will keep on moving forward.

Thanks again for your continuous support.

Regards,



André Noreau  
President  
PREMIER TECH CHRONOS

February 2005   Issue 02	
In this newsletter	
02	>>> Some statistics
	>>> Concrete mix in plastic bags...What?
03	>>> A true customer relationship
04	>>> What's new in RD&I?
06	>>> Gardenscape : a satisfied customer
	>>> Upcoming trade shows & events
07	>>> Continuing sweet success for CHRONOS RICHARDSON
	>>> Our offices worldwide
08	>>> Have you surfed our web today?

## SOME STATISTICS

### ON PREMIER TECH PACKAGING BUSINESS AREA

PREMIER TECH CHRONOS	CHRONOS RICHARDSON
<p><b>a</b> &gt;&gt;&gt; <b>75</b> people involved in engineering/designing as well as administrative services</p> <p><b>m</b> &gt;&gt;&gt; <b>36</b> team members in sales and marketing</p> <p><b>e</b> &gt;&gt;&gt; <b>34</b> technical service representatives</p> <p><b>r</b> &gt;&gt;&gt; <b>140</b> team-mates involved in the manufacturing process</p>	<p><b>e</b> &gt;&gt;&gt; <b>250</b> people at Chronos Richardson Europe</p> <p><b>u</b> &gt;&gt;&gt; <b>30</b> people at Chronos Richardson Asia</p> <p><b>r</b></p> <p><b>a</b></p> <p><b>s</b></p> <p><b>i</b></p>
<p>&gt;&gt;&gt; <b>TOTAL OF 565 TEAM MEMBERS WORLDWIDE</b></p>	

## CONCRETE MIX IN PLASTIC BAGS... WHAT?

New Orleans, LA – PREMIER TECH CHRONOS participated last March to its first ever IPCMA (International Packaged Concrete Manufacturers Association) meeting as a new rumor in the industry was surfacing, that of providing end-users with plastic bags instead of the original paper valve bags.

That rumor suddenly turned into reality when Mr. Reinhold, Home Depot's VP – Building Products Division, mentioned that "all Home Depot suppliers of bagged concrete mixes will have to provide them with heat sealed plastic bags in the next little while." The message was pretty clear that Home Depot was looking for a much cleaner and stronger package with perhaps features such as a handle at the top to help consumers carry these bags around. In fact, plastic bags are much stronger than paper bags and many tests have proven it. Another factor not to forget is the fact that the glossiness



of graphics using film can easily surpass the best quality printing of paper bags. In addition to all of the advantages, certain customers have already seen a decrease in their bag material costs from paper to U-fold poly film. What else can you ask for?

The telescopic hopper is one of the features that allows the Horizontal FFS Bagger to produce a clean plastic bag of concrete mix.

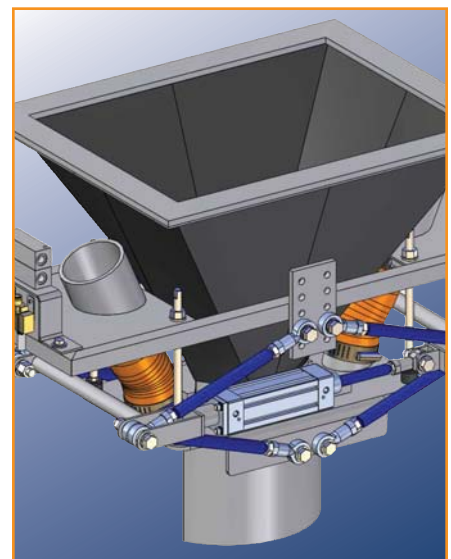

## A TRUE CUSTOMER RELATIONSHIP

### CHOOSING THE RIGHT SUPPLIER & UNDERSTANDING THE CUSTOMERS' NEEDS

It has probably happened to each one of you once to invest important sums of money in a new system and be disappointed as it is not meeting your expectations. As the equipment is put in operation, you realize that lengthy and expensive modifications are necessary to meet your specs, therefore adding delays and other constraints to your operation. Can we minimize these undesirable circumstances? Of course, but the key is to find a good supplier with a reputation who will not only claim, a supplier who will understand your needs, a supplier you will be able to create a strong relationship with.

Perhaps the most difficult task in investing in new equipment is to find the right supplier. It is fundamental to deal with the leaders that have made their marks over the years. A responsible supplier will cooperate with you along the duration of the whole project, answer your questions, resolve open issues in a timely manner and most importantly, be available to support your team during years to come. Ask for recommendations, contact users in your own field or in a similar business, visit installations. Your investment is important and needs to bring back results. It is always better to invest now than spend extras to fix problems later on. We beg you NOT to base your choice of supplier strictly on initial equipment investment but rather on the overall capabilities of the supplier. You must get answers at least to the following questions prior to signing the purchase agreement. If the answers fit within what you consider as acceptable criteria, then perhaps you should go ahead with it.

If your responsibility lies in finding the right supplier, ours as a manufacturer is to make sure we have all the data concerning your expectations, your product and the environment your equipment will operate in. Therefore, sharing your former experience with the equipment will save you a lot of problems down the road. We, at PREMIER TECH CHRONOS, have understood this concept. We have come

### CHOOSING THE RIGHT SUPPLIER, ULTIMATELY CHOOSING YOUR PRODUCTION PARTNER



- How quickly can the supplier provide you with spare parts?
- How many service representatives does the company have?
- How soon can the supplier get a technical person to your site?
- How strong is the company financially? (You want to make sure you will be able to get parts and service years down the road.)
- How much R&D does the company invest in?

a long way spending many years developing tools and equipment to meet

#### UNDERSTANDING THE CUSTOMERS' NEEDS

our own internal operation needs at our sister-company PREMIER HORTICULTURE. Today we are proud to share our expertise and our commitment to find better ways to help your business too. Joining our dedicated team, you will not only benefit from our field service representatives

but you will also be supported by our worldwide experts and professional engineers. Want us to do more, send us your questions and suggestions to [service@premiertechchronos.com](mailto:service@premiertechchronos.com). We will take care of you.

Our goal is to grow with you. You are the best in your field, we are the leader in ours, let's get our teams work together.

## WHAT'S NEW IN RD&I ?

### PREMIER TECH CHRONOS INNOVATIVE PRODUCTS

Several new products have come to reality in the last months at PREMIER TECH CHRONOS due to the great efforts of the RD&I team. One of the new products which is undoubtedly in-line with the company strategic planning of providing integrated systems is certainly the Production Data Management System (PDMS).



#### What is it?

The PDMS is an Excel-based PLC data collection software that is intended to help our customers better optimize/monitor their PREMIER TECH CHRONOS systems. Data such as starting date, time, BPMs (bags per minute), total number of units produced for the period, time down, reasons (faults), fault description are just a few items that the PDMS reports can produce, which is relevant information to be able to monitor production.

#### PDMS >>> PRODUCTION DATA MANAGEMENT SYSTEM

The collection of data is done on Excel spreadsheets which allow the users to play with the data as they see fit, perhaps producing bar graphs or pie charts when needed.

#### What's the purpose?

The typical use of this product/software will primarily be directed to the production people needing to gather more information about production on a daily basis. Typically a customer will dedicate a PC to this application alone most often remotely located from the plant itself in order to avoid any dust problems with hardware of the PC.

#### How simple is it to be connected?

Although there are a few items to acquire to be able to connect with your equipment, it certainly is quite simple to do so. Do not hesitate to contact your sales representative for additional information on the PDMS.



### SPEEDAC NXT

#### WEIGHT CONTROLLER

The **SpeedAC NXT** is now our standard platform in terms of all weight controllers used in the past by PREMIER TECH CHRONOS for its valve bagging, weighing as well as bulk bag filling systems. In time, there will be a retrofit kit available for all applications, net or gross, for all technologies.

### UBM-1030 SERIES

#### HIGH SPEED SINGLE NET WEIGHER

The **UBM-1030 Series High Speed Single Net Weigher** can handle free flowing materials at rates up to 35 BPM with accuracy of  $\pm 1$  to 3 oz. This technology, using a servomotor on the catch gate, combines the speed of a duplex weigher with all of the advantages of a simplex (reduced overall dimensions, discharge in line with the bag, lower cost, etc.) to offer the more profitable system on the market place when high outputs are required.



The **PTS Series Open-Mouth Bagger** is a high speed system designed for bagging all types of free flowing materials. Thanks to its innovative swivel spout system, pillow-type or side gusseted bags of various sizes can be filled at capacities of up to 23 bags per minute. Its compact design combined with a neat arrangement of the operating elements allows for an easy fit in tight spaces and facilitates access for the operation.



PTS SERIES  
OPEN-MOUTH BAGGER

The **LW-400 Series Rotary Arm Stretch Wrapper** has the possibility to wrap 70 to 90 loads per hour if the rate is needed. The main feature of this design is the



“pre-stretching” of the film which will make a much tighter pallet at the end. Options available are the top sheet dispenser (in-cycle or in-line), film sealer and pop-up conveyor.

LW-400 SERIES  
ROTARY ARM STRETCH WRAPPER

SOME STATISTICS

ON PREMIER TECH CHRONOS' RD&I

- >>> 22 full-time team members
- >>> Investment of approximately 2M\$ per year
- >>> 42 new technological advances issued from Mobilisateur I and II programs
- >>> Most advanced 3-D CAD software (Solid Edge) used for equipment design
- >>> State-of-the-art testing facility



>>> **OUT TO INNOVATE EVERYWHERE AT ALL TIME**

# GARDENSCAPE

## A SATISFIED CUSTOMER

Eau Claire, PA –It was back in 1998 when Gardenscape, a large North American producer of soils, mulch, salt and stone called PREMIER TECH CHRONOS to investigate the potential alliance as a supplier of bagging and palletizing systems.



Gardenscape, already using a competitor's horizontal FFS bagger wasn't 100% satisfied with the performance, reliability and after-sales service at the time. "We had to look for a true partner with complete integration capabilities," says Stu Hoffman, Gardenscape's plant manager at Emlenton, PA. "There was this new company out of Quebec which we did not know much about, but we sure could feel the dynamism of its team when we met a few of their engineers." After evaluation and consideration, Gardenscape decided to take a chance on PREMIER TECH CHRONOS.

**“ In the first 6 months of production with our new bagger, we produced 1.7 million bags with maintenance costs of less than \$ 200! ”**

**Stu Hoffman, Plant Manager at Gardenscape**

"We've improved our production drastically with much less downtime, maintenance costs are half what they were and when we face a problem, they are there to help. What else can we expect out of a supplier?" added Dave Kasmoch Jr., Gardenscape's president.

In December 2003, Gardenscape acquired another horizontal form, fill and seal (FFS) bagger from PREMIER TECH CHRONOS which is the FFS-200 series, the second generation bagger of this type. Gardenscape already had the first generation of FFS

bagger from PREMIER TECH CHRONOS.

Stu Hoffman commented with words that speak for themselves: "In the first 6 months of production with our new bagger, we produced 1.7 million bags with maintenance costs of less than \$200. We start it in the morning and shut it down at night when we leave, just impeccable." Gardenscape has now selected PREMIER TECH CHRONOS as its equipment supplier of choice for its feeding, bagging, conveying and palletizing needs. Certainly because of its integration capabilities overall, but most definitely because of its equipment design quality and great after-sales service.

## UPCOMING TRADE SHOWS & EVENTS

EXHIBITION	FOCUS	DATE	LOCATION
<b>USCC Trade Show</b>	Composting Industry	January 23-26   2005	San Antonio, TX, USA
<b>Gulf Coast Solids Handling &amp; Processing Show</b>	Handling & Processing Equipment	April 05-06   2005	Pasadena, TX, USA
<b>IAOM Trade Show</b>	Milling Industry	April 30 to May 04   2005	Nashville, TN, USA

>>> COME AND MEET PREMIER TECH CHRONOS' TEAM.

## CONTINUING SWEET SUCCESS

### FOR CHRONOS RICHARDSON IN TURKEY

CHRONOS RICHARDSON has won an important order to supply three more of its CHRONO-FILL™ PBS 1200 high speed bagging lines to Konya Seker, the largest private sugar producer in Turkey.



These lines are currently being commissioned at their new sugar refinery nearing completion at Çumra, 50 kilometres south of Konya in the highlands of Anatolia. This follows on from the order for three similar lines supplied to Konya

Seker some two years ago.

The PBS 1200 is ideal for the hygienic bagging of sugar. It features a high-speed high-reliability bag placer as well as continuous bag guidance from placing to

closing. The design minimizes dust escape throughout the filling and closing process and easy access ensures cleaning and maintenance can be carried out quickly and effectively. Changing bag sizes and types can be implemented with the minimum of disruption. The PLC control system has a user-friendly operator interface and the built-in error detection system minimizes downtime.

The original PBS lines at Konya replaced outdated mechanical bagging lines and fitting the new automatic bagging lines into the existing production area presented a number of challenges, especially given the space restrictions. However CHRONOS RICHARDSON engineers have worked closely with Konya engineers to ensure a successful outcome.

## OUR OFFICES WORLDWIDE

### A LOCAL PARTNER WITH A GLOBAL REACH

PREMIER TECH CHRONOS	CHRONOS RICHARDSON S.A.	CHRONOS RICHARDSON LTD
<p><b>Corporate Office</b> 1, avenue Premier Rivière-du-Loup (Quebec) G5R 6C1 CANADA Phone +1 418 867 8883 Fax +1 418 862 6642</p>	<p>Le parc de Viry, 14, rue de Ris 91170 Viry-Chatillon FRANCE Phone +33 1 69 12 11 50 Fax +33 1 69 12 11 59</p>	<p>Arnside Road, Bestwood Nottingham NG5 5HD UNITED KINGDOM Phone +44 115 935 1351 Fax +44 115 960 6941</p>
	CHRONOS RICHARDSON S.R.L.	CHRONOS RICHARDSON LTD
	<p>Via Edison Volta 25/A 43100 Parma ITALY Phone +39 05 21 94 08 41 Fax +39 05 21 94 08 27</p>	<p>333/3 Sukhumvit Soi 71 Road Prakanong-Nua, Wattana Bangkok 10110, THAILAND Phone +44 115 935 1351 Fax +44 115 960 6941</p>

>>> TO CONTACT US BY EMAIL : [INFO@PREMIERTECHCHRONOS.COM](mailto:INFO@PREMIERTECHCHRONOS.COM)

Place  
stamp  
here

PREMIER TECH CHRONOS  
1, avenue Premier  
Rivière-du-Loup, Qc  
CANADA G5R 6C1



## HAVE YOU SURFED OUR WEB TODAY ?

[WWW.PREMIERTECHCHRONOS.COM](http://WWW.PREMIERTECHCHRONOS.COM) [WWW.CHRONOSRICHARDSON.COM](http://WWW.CHRONOSRICHARDSON.COM)

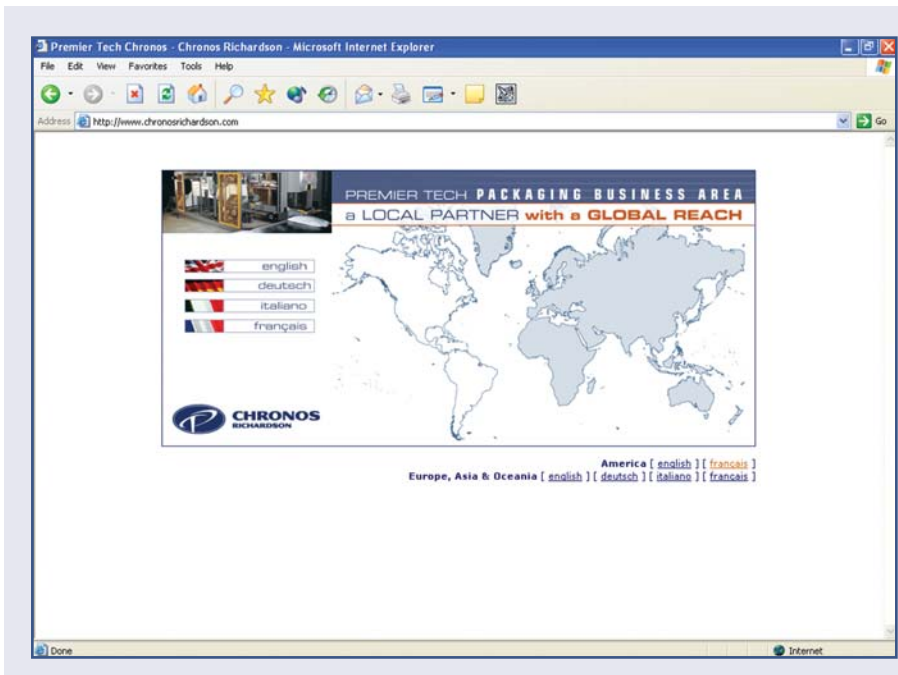

If not, take a few moments to check out our newly integrated web site at :  
**[www.premiertechchronos.com](http://www.premiertechchronos.com) or [www.chronosrichardson.com](http://www.chronosrichardson.com).**

Our new site provides web surfers with the opportunity to come in closer contact with all of PREMIER TECH's packaging technologies including all products from CHRONOS RICHARDSON, our European and Asian business unit, as well as Richard Simon's product lines both totaling over 200 years of experience in the Industrial Flexible Packaging world.

**HAVE A GREAT VISIT !**